

GENETIC ENGINEERING USING HOMOLOGOUS RECOMBINATION¹

Donald L. Court, James A. Sawitzke, and
Lynn C. Thomason

*Gene Regulation and Chromosome Biology Laboratory, Center for Cancer
Research, National Cancer Institute at Frederick, Frederick, Maryland 21702;
e-mail: court@ncifcrf.gov, sawitzke@ncifcrf.gov, lthomason@ncifcrf.gov*

Key Words DNA replication forks, strand annealing, in vivo cloning, oligo recombination, recombineering

■ **Abstract** In the past few years, in vivo technologies have emerged that, due to their efficiency and simplicity, may one day replace standard genetic engineering techniques. Constructs can be made on plasmids or directly on the *Escherichia coli* chromosome from PCR products or synthetic oligonucleotides by homologous recombination. This is possible because bacteriophage-encoded recombination functions efficiently recombine sequences with homologies as short as 35 to 50 base pairs. This technology, termed recombineering, is providing new ways to modify genes and segments of the chromosome. This review describes not only recombineering and its applications, but also summarizes homologous recombination in *E. coli* and early uses of homologous recombination to modify the bacterial chromosome. Finally, based on the premise that phage-mediated recombination functions act at replication forks, specific molecular models are proposed.

CONTENTS

INTRODUCTION	362
RECOMBINATION FUNCTIONS IN <i>E. COLI</i>	364
Strand Invasion Versus Single-Strand Annealing	365
THE BACTERIOPHAGE λ RED FUNCTIONS:	
EXO, BETA, AND GAM	366
λ Exo: A 5' to 3' dsDNA-Dependent Exonuclease	367
λ Beta: A ssDNA-Binding Protein that	
Anneals Complementary DNA Strands	367
λ Gam: A Modifier of RecBCD and SbcCD	368
GENE MODIFICATION AND REVERSE GENETICS IN <i>E. COLI</i>	369
Classical Genetics and Early Genetic Engineering Methods	369

¹The US Government has the right to retain a nonexclusive, royalty-free license in and to any copyright covering this paper.

Transformation and Recombination with Linear DNA	370
Bacterial-Encoded Systems for Linear DNA Recombination	371
Phage-Encoded Systems for Linear DNA Recombination	371
Genetic Engineering with Short DNA Homologies: Recombineering	372
APPLICATIONS OF RECOMBINEERING WITH LINEAR dsDNA	374
Targeting the Chromosome	374
Targeting Plasmids	375
In vivo DNA Retrieval by Gap-Repair	375
In vivo Cloning by Gap-Repair	376
RECOMBINEERING WITH ssDNA	376
Chromosome Recombineering with ssDNA Oligos: A Model	378
RECOMBINEERING WITH dsDNA: AN INTERMEDIATE	378
Chromosome Recombineering with Linear dsDNA: A Model	379
Blocking Branch Migration by a Large Nonhomologous Region: A Modified Model	379
RECOMBINEERING: TAPPING ITS POTENTIAL	380

INTRODUCTION

Recombinant DNA constructs made in vivo via homologous recombination have been a fundamental analytical tool used by bacterial geneticists. Homologous recombination is the process of exchanging DNA between two molecules through regions of identical sequence. In this way, it ensures precise exchange and joining of two DNA molecules with the limits of the exchange events defined by the homologies between molecules. Homologous DNA recombination systems are extremely useful for moving mutations into and out of the bacterial chromosome. However, these manipulations require extensive in vitro engineering of plasmids or phages in the initial stages of the protocol. Thus, the ability to create specific changes on the chromosome of *E. coli* has always been time-consuming and in certain instances very difficult. We touch on homologous recombination in *E. coli*, and ways in which it has been used to modify the bacterial chromosome. In addition, this review describes phage-encoded homologous recombination systems including very recent technological advances that eliminate the need for restriction enzymes and DNA ligase for modifying or subcloning DNA, thereby eliminating many of the time-consuming in vitro steps of genetic engineering. The phage systems described here share properties with the yeast double-strand break repair system (107, 143) that is able to generate recombinants between linear duplex DNA and the yeast chromosome through very short (<50-bp) regions of DNA identity (6). Because of this ability, yeast researchers have had an advantage that until recently was not shared by the *E. coli* geneticist. Genetic engineering with phage-encoded recombination functions that utilize short homologies has been named “recombineering,” a convenient term to describe homology-dependent, recombination-mediated, genetic engineering (29, 38).

The discovery of restriction enzymes more than 30 years ago and their use with DNA ligase to cleave and join novel combinations of DNA molecules in vitro

revolutionized molecular biology and led to the advent of genetic engineering. Since then, many advances in genetic engineering have occurred that have allowed the technology to keep up with the rapid expansion of the field of molecular biology. We are now in a new era of biology. Genomic sequencing has provided the complete genome information for many bacterial and eukaryotic organisms. At the same time, *E. coli* vectors have been developed that accommodate clones containing 100s of kb of foreign DNA, thus enabling full-length eukaryotic genes to be isolated and studied with their regulatory regions. Bacterial artificial chromosomes, BACs, or P1 artificial chromosomes, PACs, are single-copy cloning vectors derived from F or P1 plasmids, respectively (58, 128, 141). They contain the F or P1 replication and partitioning systems that ensure low copy number and faithful segregation. The complete genome of herpes virus has been cloned in one BAC (11), and complete genomic libraries from many eukaryotic organisms are represented in BAC vectors (128). Making these large clones in *E. coli* is only the beginning of the manipulations and functional analyses that are being attempted with eukaryotic genes. The full gamut of genetic tests that were once reserved for *E. coli* and yeast studies are now commonplace in the mammalian model, mouse. Mouse genomic clones modified in *E. coli* can be reintroduced into the mouse genome as random transgenic events or more specifically by homologous recombination as replacements of the native segments. Subtle modifications, like point mutations, and more complex changes, like insertions, often need to be made to the BAC clones before reintroduction into their original chromosomal location. It is at this point that classical genetic engineering has become the rate-limiting step in the functional analyses of many of these large clones. The problems encountered in trying to engineer nearly megabase-size clones are the same as those faced by microbial geneticists in modifying the 4.6-megabase bacterial chromosome.

Precision in generating recombinant DNA molecules by standard genetic engineering techniques with restriction enzymes and DNA ligase is lost when working with large DNA molecules. Most cloning techniques depend upon unique restriction sites. With large DNA molecules, even rare cutters, such as the *NotI* enzyme, have many sites of action. Additionally, large DNA can be difficult to work with in vitro because it is prone to breakage. Homologous recombination in vivo is a more versatile and precise way to engineer large DNA molecules (6, 98, 155). Phage-mediated homologous recombination systems, such as the bacteriophage λ Red system, have recently been exploited for these purposes (78, 94, 99, 156, 159). These systems have critical differences from the standard *E. coli* RecA-dependent recombination pathways. The phage systems have a unique advantage in that they can catalyze efficient recombination with very short regions of sequence homology (<50-bp). Importantly, they function even in the absence of RecA, a protein essential for *E. coli* homologous recombination. This is an advantage since RecA action can lead to unwanted recombination and rearrangement of large genomic clones on BACs (29, 98, 128).

In contrast to classical genetic engineering techniques, recombineering does not require construction of plasmid or phage DNA intermediates containing the

appropriately pre-engineered homology segments. All that is required *in vitro* is the synthesis of standard oligonucleotides (oligos) that provide the homology. These oligos can be used directly for recombineering or for construction of PCR products that are used for recombineering. For effective gene replacements, the PCR products are generated with ~ 50 -bp ends that are homologous to sequence targets in the genome.

This review describes the functions of the λ Red recombination system, with emphasis on their use in homologous recombination and in recombineering. Technological advances of recombineering are but one aspect of the review; the recombination of linear DNA by the λ Red system has provided new insights into the mechanisms of homologous recombination. Based on the results of recombineering studies, molecular models describing the λ Red-mediated recombination process are proposed.

RECOMBINATION FUNCTIONS IN *E. COLI*

Homologous recombination has been studied extensively in *E. coli*. Although investigated originally because of its usefulness in genetics, a primary role of homologous recombination in the cell is almost certainly the repair of DNA damage (14). A major portion of this repair occurs at the replication fork itself, and homologous recombination is now known to be a major factor in re-establishing a stalled or disrupted replication fork (32, 57, 73). Skalka first invoked the interplay of replication and recombination processes using phage λ as a model (134, 135), but it is only recently that a direct involvement of recombination functions in the formation and/or activation of a replication fork have been demonstrated (4, 66, 74, 123).

In *E. coli*, most recombination depends on RecA. RecA protein binds to single-strand segments of DNA, forming DNA-protein filaments that have the ability to search other DNA molecules for sequence homology. Once homology is found, the RecA filament pairs and can exchange strands with the homologous segment (Figure 1) (74, 120). The RecBCD and RecF recombination systems operate in *E. coli* and both require RecA function (25, 56). The RecBCD enzyme initiates recombination at double-strand DNA (dsDNA) ends by generating 3' single-strand DNA (ssDNA) overhangs (69, 74, 100). The enzyme also aids RecA in binding to this ssDNA, allowing RecA to promote strand exchange and subsequent



Figure 1 RecA-mediated single-strand invasion and Beta-mediated single-strand annealing.

recombination (3). The RecF pathway also initiates recombination at dsDNA ends, but at a much reduced (100-fold) frequency; this represents the residual recombination activity in a *recBC* mutant (39). Perhaps the most important function of the RecF pathway is to repair defective replication forks (32, 74). Although the RecF pathway requires a broader set of proteins to carry out the recombination reactions than the RecBCD pathway, similar enzymatic functions are needed. For example, RecQ and RecJ process dsDNA to generate 3' ssDNA overhangs for RecA binding (30). The RecO, RecR, and RecF proteins enhance binding of RecA protein to these single-strand substrates in the presence of single-strand DNA-binding protein, Ssb (147). Once RecA is bound to ssDNA, homology search and strand exchange generate recombination intermediates that may require DNA synthesis to fill any gaps. Recombination intermediates (Holliday structures) in both pathways can be resolved by the process of branch migration catalyzed by RuvAB or RecG, and endonucleolytic cleavage catalyzed by RuvC (127). DNA ligase seals any nicks remaining after resolution.

Additionally, phage-mediated recombination systems can be provided in *E. coli* by the Rac prophage functions, RecE and RecT, or the λ phage Red functions, Exo and Beta. Under some conditions, the phage systems use RecA function (139, 140); however, the phage systems can also generate recombinants in the complete absence of RecA (10, 129).

Strand Invasion Versus Single-Strand Annealing

A primary difference between RecA-dependent recombination and the RecA-independent phage-mediated recombination is the way in which homologous pairing and strand exchange occurs. The RecA-independent Red-mediated recombination is comparatively simple. As defined both *in vivo* and *in vitro*, the Red functions Exo and Beta generate recombinants by a process called single-strand annealing (Figure 1) (17, 55, 139, 140). If two homologous DNAs each receive a double-strand break at different points, Exo can degrade the 5' ended strands exposing 3' overhangs that Beta binds. Once the complementary sequence is exposed, Beta can anneal the two strands to generate recombinants. In comparison, RecA-mediated exchange can also progress by single-strand annealing, but often occurs through a strand invasion mechanism. RecA bound to the 3' end of ssDNA can find homologous unbroken DNA and invade, generating the recombination intermediate shown in Figure 1 (74). As described above, additional functions can complete the recombination. Thus, the mechanics of strand invasion promoted by RecA and strand annealing promoted by Red are two well-defined alternatives to generate recombination products. A point relative to the discussion of recombineering is that the Red system cannot generate recombinants between a linear DNA duplex and a nonreplicating DNA circle in the absence of RecA (112, 140). However, the Red system can generate recombinants between linear DNA and the bacterial chromosome in the absence of RecA (97, 156), presumably because the circular chromosome is replicating.

THE BACTERIOPHAGE λ RED FUNCTIONS: EXO, BETA, AND GAM

Mutation of *recA* (24) eliminates recombination mediated by the two bacterial systems (22, 56); however, recombination between phage λ genomes is nearly as efficient in *recA* mutants as in wild-type *E. coli* (10) because λ encodes its own recombination functions. The *exo* (*red α*) and *bet* (*red β*) genes of phage λ are defined as mutations that eliminate λ homologous recombination in a *recA* mutant strain (36, 41, 130). Some of the *bet* mutations not only cause a Beta defect, but also are defective for λ exonuclease (Exo) activity (129, 157). Polarity is not the only cause of this double defect; in some cases a defective interaction between mutant Beta protein and Exo is thought to reduce the exonuclease activity (129). The notion that the two proteins interact is further supported by the copurification of Beta and Exo in a complex (118).

A third gene, *gam*, provides the full recombination potential to λ . Genetic studies first indicated that RecBCD was a target for Gam (161), and that Gam binds to the RecB subunit (87, 122). Although the RecBCD enzyme is present at only 10 molecules per cell (145), it aggressively destroys most cellular linear dsDNA. By binding, Gam protein inhibits this potent nuclease (63, 93). Other genetic studies indicated that Gam inhibited a second function of *E. coli*, the SbcCD endonuclease (20, 44, 70). Sequence comparison studies show that SbcC and RecB are derived from a common ancestral protein (102), thus a common binding site may remain. In vitro studies with purified SbcCD demonstrate an endonuclease activity targeted to DNA palindromes, which is accompanied by a processive dsDNA-dependent 3' to 5' exonuclease activity (27, 28). In vivo, SbcCD repairs double-strand breaks on the bacterial chromosome through recombination with a sister chromosome (33). Thus, Gam inhibits two nucleases, RecBCD and SbcCD, both involved in double-strand break-dependent recombination.

The *exo*, *bet*, and *gam* genes are located next to each other in the *p_L* operon of phage λ (Figure 2) and are expressed early following infection by the phage or after induction of the prophage. In the prophage, the *p_L* promoter is directly controlled by the CI repressor, and even following removal of the repressor the expression of the *exo*, *bet*, and *gam* genes is initially prevented by transcription termination. Ultimately, λ N function modifies RNA polymerase to prevent



Figure 2 The *p_L* operon of prophage λ . The *p_L* promoter transcribes the genes to its left in the map. *T* represents a transcription terminator. The recombination functions Exo, Beta, and Gam are shown above their genes. Other genes are described elsewhere (31).

transcription termination and allow expression of the recombination functions (31), thereby coordinately activating all the genes in the p_L operon.

A cryptic λ -like prophage, called Rac, is found in the genome of some strains of *E. coli*. This prophage contains genes, *recE* and *recT*, encoding homologous recombination functions that are analogous to *exo* and *bet* (48, 60, 61). Mutants in Rac called *sbcA* (suppressor of *recBC*) have been selected in which expression of these genes has been activated resulting in increased recombination in the absence of RecBCD (5). Our discussion focuses primarily on the λ Red gene functions, but they are very similar in activity and function to RecE and RecT. In fact, RecE and RecT can substitute for Exo and Beta on λ (47).

λ Exo: A 5' to 3' dsDNA-Dependent Exonuclease

λ Exo has a subunit molecular weight of 24 kDa and degrades linear dsDNA in a 5' to 3' direction processively at a rate of 1000 bases per second in vitro (16, 80, 88). Single nucleotides are removed processively leaving long, 3' ssDNA overhangs (Figure 3) that can reach almost half the length of the original duplex DNA (16, 55, 80). Exo requires a dsDNA end to begin digestion and remains bound to the dsDNA as it degrades one strand; it does not initiate at nicks or gaps in the DNA (17, 18). The active form of the protein is a trimer that has a central hole (68, 150). While the entrance to the hole accommodates a dsDNA, the exit diameter is the size of ssDNA. Thus, Exo binds a dsDNA end, slides down the 3'-ended strand, and cleaves mononucleotides from the 5' strand, leaving behind the intact 3' overhang (68). Exo also has a much weaker 5' exonuclease activity on short ssDNA oligos (138).

A novel activity of Exo is displayed during strand assimilation (Figure 3). In situations where Exo is degrading a dsDNA from its 5' end, a complementary single-strand DNA may be annealed to the 3' single-strand overhang being generated by degradation. Exo degradation of the 5' strand is prevented as soon as the strand annealing is complete, leaving a nick at that point (18). A nick may also be generated through the combined strand assimilation actions of Exo and Beta as shown in Figure 3 (79).

λ Beta: A ssDNA-Binding Protein that Anneals Complementary DNA Strands

The λ Beta protein has a subunit molecular weight of 25.8 kDa. When isolated from the cell, Beta copurifies with λ Exo and two other proteins until the final phosphocellulose step. Even after this step, most of the Beta protein remains associated in a high-molecular-weight complex with the two other proteins, the S1 ribosomal protein and the NusA transcription elongation factor (91, 151). It is not known whether this interaction occurs in vivo or whether NusA and/or S1 affect recombination.

The Beta protein binds stably to ssDNA (118) greater than 35 nucleotides in length (101), and protects the DNA from single-strand nuclease attack (62, 92).

Beta promotes pairing or annealing between complementary ssDNAs, (Figure 3) (62, 65, 92). Although Beta does not bind directly to dsDNA (62, 92), after it anneals complementary ssDNAs, it remains tightly bound to the annealed duplex (62, 79, 92). This annealed dsDNA-Beta complex is resistant to DNase I and is much more stable than the ssDNA-Beta complex (79). Thus, Beta is bound to duplex DNA but only as the nascent product of strand annealing.

Beta spontaneously assembles into a ring structure in solution and when bound to ssDNA, as it anneals strands it forms a filament on dsDNA (109). Similar ring and filament structures have been found for several other proteins that bind and anneal ssDNA to a complementary sequence, including the yeast RAD52 protein (109). Beta enters the ssDNA at the 3' end and loads in a polarized manner, binding from 3' to 5' (62, 79). Since Exo and Beta are thought to form a complex *in vivo* (18, 129), it is reasonable that they act cooperatively such that Exo degrades the 5' ends of duplex DNA revealing 3' ssDNA to which Beta can bind. For RecE and RecT, such a combined activity has been demonstrated *in vitro* (49).

In addition to promoting strand annealing, Beta can also promote a limited type of strand exchange. It can displace a strand of a DNA duplex but must have an adjacent single-stranded gap for initiating the annealing reaction; Beta can then promote displacement using only the energy gained by the adjacent annealing reaction. Beta cannot directly invade duplex DNA with a homologous ssDNA as RecA does (79). RecT has been shown to carry out a similar single-strand displacement of duplex DNA adjacent to gaps (49). RecT-mediated strand invasion into supercoiled circular DNA has been demonstrated *in vitro* under conditions of low salt and in the absence of divalent cations (103). It remains an open question as to whether strand invasion occurs *in vivo* during Beta- and/or RecT-dependent recombination events in the absence of RecA. The phage systems have been proposed to cause strand invasion in the absence of RecA (71, 83, 133, 144). However, Kuzminov has explained the same events by single-strand annealing reactions (74).

λ Gam: A Modifier of RecBCD and SbcCD

The λ Gam protein binds stoichiometrically to the RecBCD enzyme forming the RecBCD-Gam complex (63, 93). In this complex, several activities, including the nuclease activities, of RecBCD are inhibited (63, 93, 148). A more recently defined activity of RecBCD has not been tested for Gam inhibition, the loading of RecA protein onto ssDNA (2, 3, 21).

If Gam completely inactivates RecBCD, bacterial strains expressing Gam should have the same phenotypes as a RecBCD null mutant. Indeed, both cell types exhibit similar phenotypes; they allow DNA concatemers to form during λ replication (42, 114), generate concatemer-like multimers during ColE1 plasmid replication (26, 40, 131, 132), are UV sensitive, and show reduced cell viability in culture (42, 93).

One major difference between the two cell types is that the strain expressing Gam maintains a high level of recombination activity, arguing against the idea that

Gam completely inactivates RecBCD. In the presence of Gam, recombination is retained for both Hfr crosses and P1 transductions (51, 93, 116) and is actually stimulated for the repair of double-strand breaks caused by X rays (146). Moreover, recombination in phage λ crosses in which Gam (but not Exo or Beta) is present is also efficient (129). These different types of recombination still require RecBCD function since *recBC* or *recD* mutants are defective for recombination or repair in the presence of Gam (93, 116, 146, 148). Thus, Gam does not inhibit a RecBCD-dependent recombination activity despite greatly altering the activity of the RecBCD enzyme. Gam does, however, create new requirements for this altered RecBCD recombination. Several studies show that Gam-inhibited RecBCD recombination and repair requires RecA, RecJ, RecQ, and RecN of the RecF pathway but not RecF itself (82, 93, 108, 146). These proteins likely provide the RecBCD enzymatic activities inhibited by Gam. RecF, a function involved in loading RecA onto ssDNA (147), is not required, indicating that RecBCD-Gam may retain this activity (108). Thus, the RecBCD-Gam complex retains some RecBCD function but requires components of the RecF pathway. It remains a possibility that the SbcCD recombination function (33) retains a residual activity when complexed with Gam and that the two complexes, RecBCD-Gam and SbcCD-Gam, both contribute to recombination.

GENE MODIFICATION AND REVERSE GENETICS IN *E. COLI*

The plasmid and phage vectors, so well studied in *E. coli*, provide great advantages for cloning, amplification, and manipulation of foreign DNA. These methods depend upon classical genetic manipulations as well as standard recombinant DNA techniques such as cutting DNA with restriction endonucleases, purifying DNA fragments, making novel DNA joints with DNA ligase, and transforming the clones into competent cells. Recombineering can replace many of these tedious manipulations.

Classical Genetics and Early Genetic Engineering Methods

In *E. coli*, the earliest systems for manipulating genes and mutant alleles involved moving them from one strain to another by conjugational mating of an integrated F (Hfr crosses) or by F' elements (F plasmids that carry specific segments of bacterial DNA). Transduction by phages that carry bacterial DNA was also used to transfer markers from one strain to another.

As cloning of genes came into vogue, bacteriophage λ vectors were used to clone nearly every gene of *E. coli* (67). These vectors were deleted for λ recombination functions. Genetic modifications of the cloned genes could be engineered on λ and then exchanged from λ to the chromosome (52). Allelic exchange of this type was usually accomplished by forcing the λ to integrate and later excise using homology shared between the cloned gene and the chromosome (Figure 4).

These two events, integration and excision, are dependent upon RecA (46, 84), and occur at frequencies approaching 1 in 1000 cells.

Similar RecA-dependent homologous recombination methods have been used to exchange alleles between plasmid clones and the bacterial chromosome (119). Generally, the system is set up so that the plasmid is conditionally defective for replication and can only be maintained if it is integrated via homologous recombination between its cloned gene and the bacterial chromosome (50, 105, 136, 155). These integrants are normally selected via a drug resistance conferred by the plasmid. These plasmid and phage systems are ideal for transferring specific modifications made *in vitro* back onto the chromosome (Figure 4). However, they rely on cloning the homologous regions onto the vectors and creating the desired changes *in vitro*, which may entail additional cloning and testing stages (Figure 5A). Another limitation with these integration and resolution systems is that the integrated form may cause polarity on downstream genes within an operon. Thus, integrations cannot easily be made and tested where essential genes are involved.

Transformation and Recombination with Linear DNA

Homologous recombination can be used to recombine a linear dsDNA fragment into the genome. This type of allelic replacement was first commonly utilized in *Saccharomyces cerevisiae*. In yeast, because double-strand break repair recombination is very proficient and is stimulated by linear DNA ends (143), recombinants are readily created between homologous segments of the chromosome and transformed DNA. The homology segments at the ends of the linear DNA can be as short as 50-bp. Such linear DNAs flanked by short homologies can be generated directly by PCR using primers carrying the 50-bp homologies (6, 75). This recombination technology is extremely useful because it allows direct *in vivo* engineering of the chromosomes and plasmids in yeast without the time-consuming and cumbersome efforts required in generating clones and modifications of clones *in vitro* using restriction enzymes and DNA ligase. Figure 5B illustrates the steps involved in constructing chromosomal allelic replacements using these short homologies on linear DNA. Yet, there are serious limitations in using yeast for more general recombinant DNA procedures. Yeast does not have vectors for shuttling engineered DNA to organisms other than *E. coli*, and it is difficult to produce and isolate sufficient levels of plasmid from yeast cells. Finally, the recombination activities in yeast are intrinsic and are not controllable for genetic engineering. For these reasons, a regulated system in *E. coli* that mimics the powerful genetic techniques provided by yeast homologous recombination would be an invaluable tool. Early attempts to develop such bacterial or phage systems, described below, were limited in their usefulness because of their requirement for long homologies and their poor efficiencies. More recently, a phage-encoded system that allows direct modification of the bacterial chromosome as well as *E. coli* vectors including BACs that can contain large DNA inserts (~300 kb) has been developed

(29, 98, 111). This latest technology, called recombineering, has advantages over all previous systems.

Bacterial-Encoded Systems for Linear DNA Recombination

In wild-type *E. coli*, unlike yeast, linear dsDNA is rapidly degraded by nucleases. *E. coli* mutants that are defective for the main nuclease, *recB* or *recC*, do not degrade linear DNA as rapidly (8, 9), are defective for recombination, and grow very poorly, producing up to 80% nonviable cells (15). Suppressor mutations, *sbcB* *sbcC*, restore recombination activity and viability to these *recBC* mutant strains (5, 72, 81). The *sbcB* mutation is a special allele of the *xonA* gene, which affects the 3' to 5' exonuclease activity of Exo I. As mentioned above, *sbcC* encodes part of another RecBCD-like nuclease. Linear DNA is stable in these suppressor strains and can undergo homologous recombination with the chromosome using the RecF pathway. This recombination is completely dependent upon RecA (23). In *recBC* *sbcB* *sbcC* mutant cells, recombination requires very long regions (~1000 bp) of flanking homology that must be engineered by classical cloning techniques and isolated as linear DNA by restriction digestion. Despite the long homologies, the frequency of recombinants is low and requires microgram amounts of transformed DNA (59, 86).

The RecBCD functions can also be used for linear DNA recombination under specific conditions. Mutations in the *recD* gene inactivate the RecBCD nuclease but not recombination activities and thus, linear DNA is preserved and can be recombined with the chromosome (121). Dabert & Smith (34) used another approach to recombine linear DNA in wild-type *E. coli* containing the RecBCD nuclease. Special sites were engineered in the linear DNA causing RecBCD that entered these DNAs to lose its destructive nuclease activity and to become recombinogenic. In fact, electroporation itself has been suggested to reduce DNA degradation by RecBCD nuclease and allow recombination with linear dsDNA (37). Thus, several different strategies have been utilized to allow linear DNA recombination in *E. coli*; all require RecA and either the RecF or RecBCD recombination pathway functions. Unfortunately, all are very inefficient, with only a few recombinants found per transformation. In addition, thousands of base pairs of homology and high DNA concentrations are required to generate these rare recombinants.

Phage-Encoded Systems for Linear DNA Recombination

Another class of *recBC* suppressor mutations, *sbcA*, that expresses recombination functions RecE and RecT (48) from the λ prophage, also generates rare recombinants between linear DNA and the host chromosome or plasmids (152). A similar system, Red, is encoded by phage λ . Murphy (94) developed the λ system, which enhanced the efficiency of linear DNA recombination at least 50-fold compared with previous systems. Moreover, this λ recombination is functional in most strains, not just *recBC* or *recD* mutants. In this Red system, the λ *exo*, *bet*, and *gam* genes are under *lac* promoter control on a multicopy plasmid. Because Gam function inhibits

RecBCD nuclease, and because Exo and Beta provide recombination activity, linear DNA is not degraded but recombines with the circular bacterial chromosome. In the wild-type strain, a similar plasmid that expressed only Exo and Beta (no Gam) did not generate recombinants under the same conditions, demonstrating again the inhibitory effect of RecBCD nuclease. Murphy (94) also demonstrated that the phage P22 recombination functions could promote linear recombination but at a reduced efficiency relative to the λ functions.

When the λ *gam* gene is expressed, ColE1 plasmids fail to replicate as circles and generate linear multimers (26, 114, 132). These multimers can inhibit recombination between linear transformed DNA and the chromosome, perhaps because they compete for the Exo and Beta products (94). The plasmid concatemers may also be toxic to cells containing them (42). For these reasons, Murphy (94) replaced the chromosomal *recBCD* operon with the λ *exo* and *bet* genes under *lac* promoter control. Conveniently, in this *recBCD* replacement, Gam was not required to inactivate the RecBCD nuclease. Despite being expressed from a single copy in the chromosome, Exo and Beta functions increased linear recombination several-fold over the plasmid-induced level. The Poteete and Murphy laboratories (94, 95, 113, 115) have shown that linear recombination in these *recBCD::P_{lac} bet exo* cells is completely dependent upon the λ Exo and Beta functions. Recombination levels are also dependent upon RecA as they are reduced nearly 100-fold in *recA* mutants. In addition, several recombination genes, *recQ*, *recO*, *recR*, *recF*, and *ruvC*, were required, but *recJ* and *recG* were not. Thus, recombination generated in this *recBCD* deletion mutant background uses a combination of the Red and RecF pathway functions and is largely dependent upon RecA. In these studies, long homologies (> 1000 bp) between the linear DNA and the chromosome were used. Recombination was enhanced by increasing the time of Exo and Beta induction (94) and by increasing the linear DNA concentration (95). At very high concentrations of linear DNA (~30 micrograms per electroporation), recombinants were found in 1% of the cells surviving electroporation.

Genetic Engineering with Short DNA Homologies: Recombineering

Homologous recombination studies and in vivo genetic engineering were taken to yet another level by Francis Stewart and colleagues (159). They found that short DNA homologies, 42 to 50 bp in length, generated recombinants that depended upon expression of the RecE and RecT functions induced in the *recBC sbcA* mutant strain described above. Although this RecET-mediated recombination is not very efficient, the crucial advantage is that it could use short homologies (159). This technology is extremely useful for genetic engineering of BAC or PAC clones and the chromosome of *E. coli* (99, 159). The homology required could be incorporated in the primers used to PCR amplify the drug cassette, thereby eliminating multiple steps: namely, the need for in vitro construction of plasmids containing the long (> 1000 bp) flanking homologies (Figure 5).

The Stewart laboratory (159) created a portable system by cloning *recE*, *recT*, and the λ *gam* genes under control of three separate promoters in a ColE1-type plasmid. Although transferable, this plasmid-based system is poorly maintained and somewhat toxic due to *gam* expression. Of the three genes, only the *recE* gene was placed under a regulated promoter, the arabinose *pBAD* promoter; *gam* and *recT* were placed under constitutive promoters. Expression of Gam inhibited RecBCD nuclease, allowing linear DNA to survive and the short homologies at the DNA ends to be used as substrates for the recombination functions of RecET. The plasmid construct generated ~threefold more recombinants than the chromosomal *recBC sbcA* mutant (159). Thus, a flexible system that could generate linear DNA recombinants in most strains using short homologies was created. Another very similar plasmid construct was created that substituted the λ *exo* and *bet* genes for *recE* and *recT*, respectively. This Red system worked as well if not better than the RecET system (99). These same plasmid sets have also been designed without *gam* and have been used by the Stewart laboratory (97) in *recBC* mutant strains, while other plasmid replicons derived to express the *gam*, *bet*, and *exo* genes include pSC101 (35) and pR6K116 containing the R6K gamma origin of replication (160).

A defective λ prophage-based system has also been developed to express *gam*, *bet*, and *exo* genes in their natural context. Here the genes are carried as a single copy on the bacterial genome and expressed from the powerful λ *p_L* promoter. Expression is tightly regulated by the temperature-sensitive λ CI857 repressor (Figure 2); at 32°C the repressor blocks the *p_L* promoter. Inactivating the repressor by a temperature shift to 42°C turns on the promoter, allowing coordinated expression of *gam*, *bet*, and *exo* genes (156).

In plasmid and prophage recombineering systems that use short homologies, linear DNA recombination requires both *exo* (*recE*) and *bet* (*recT*) expression; *gam* is also required in *recBCD*⁺ cells (97, 156). Muyrers et al. (97) demonstrated that RecE works only with RecT and that Exo works only with Beta. Mutation of *recA* only reduced this recombination a few fold (97, 156). This differs from the Murphy and Poteete laboratories' Red-mediated system that uses long homologous ends. In that system, the absence of RecA causes up to a 100-fold reduction in recombination (94, 95, 113, 115). This discrepancy is not understood (111); however, homology length does not appear to be the cause (97, 156).

The plasmid- and prophage-based recombineering systems each have their advantages and disadvantages. Generally, the plasmid system is more mobile and easily transferred among *E. coli* strains and even to other bacterial species (117, 149). Recombination functions in the prophage system are tightly controlled and coordinately expressed. Three problems are avoided by being able to coordinately induce the prophage recombination functions for a brief (<15 min) time: (a) Leaky expression of recombination functions leads to unwanted recombination products. This is more of a problem with BAC (or PAC) clones carrying genomic DNA from eukaryotes that possess many long repetitive sequences. (b) Constitutive expression of Gam function inactivates RecBCD leading to plasmid instability (26, 40,

93) and cell toxicity (42, 126). (c) Altered expression ratios of RecE and RecT functions affect recombination efficiency (97).

Coordinate expression of the Exo and Beta functions from their natural context in the prophage generates especially high recombination levels, which can be a great advantage. In fact, Lee et al. (78) were able to identify recombinants by colony hybridization without selection. In their experiment, a 24-bp sequence encoding the FLAG TAG epitope had been targeted by flanking homology to a gene in a BAC clone in a *recA* mutant background. Seven colonies in 4200 examined from the electroporation hybridized to the 24-bp probe, and all seven were found to be correct by sequence analysis.

APPLICATIONS OF RECOMBINEERING WITH LINEAR dsDNA

Targeting the Chromosome

Antibiotic cassettes with appropriate flanking homology can be conveniently used to target specific genes or regions of the chromosome for replacement. Such replacements are directly selected as drug resistant. The junctions between the homology arms and the start of the resistance cassette define the ends of the deleted region (see Figure 5B). This technology has been used to insert cassettes between two adjacent base pairs without deleting any bases (38, 159) and to replace as much as 70-kb with the cassette (54).

In addition to the selectable marker, other DNA sites or coding sequences can be incorporated on the same fragments as the resistance cassette and recombined jointly with it. Examples include *lacZ* fusions, GFP fusions, and His-tags. The limiting condition in these cases is usually the size of the DNA elements to be amplified and the fidelity of the PCR amplification of those elements. Targets for site-specific recombinases, such as *loxP* or *frt* sites, can be added on the flanks of the drug cassette, allowing subsequent removal of the cassette by activating expression of site-specific recombinases Cre or Flp that act on *loxP* and *frt* sites, respectively (35, 99, 159). Counter-selectable genes such as *sacB* can also be recombined along with the selectable drug marker. The SacB function, once established in a cell, converts sucrose to a toxic form and kills *E. coli* (43). A second round of linear recombination can be used to delete the drug cassette and *sacB* by plating the recombination mixture on agar containing sucrose to select for these recombinants (78, 95, 96). This counter-selection technique can generate a perfect deletion of the drug cassette and *sacB*, whereas the *loxP* or *frt* recombination always leaves behind a scar of the remaining *loxP* or *frt* site. The counter-selection technique can also be used to insert other nonselectable markers such as fusions or tags or even point mutations at the original site of recombination. Thus, a targeted region can be replaced by *cat-sacB* in the first step; then DNAs containing various mutations can be introduced in the second step, allowing selection of numerous site-specific mutations in a gene of interest.

Technically, the positive selection with a drug marker is generally free of background resistant colonies, and all resistant colonies are likely to be correct. This is not the case during counter-selection against *sacB* as spontaneous sucrose-resistant mutations, inactivated for *sacB*, occur at a frequency of about 1 in 10,000 cells. Therefore, the desired recombinants must be detected from among this spontaneous background of sucrose-resistant colonies. Screening among sucrose-resistant colonies for those that have also lost the drug cassette detects the desired recombinants. Hence, when recombination is high, fewer sucrose-resistant colonies need to be screened.

Targeting Plasmids

Just as linear DNA can be targeted to the chromosome, it can also be targeted to plasmids either already resident in the cell, or co-electroporated with linear DNA (156, 159). Both of these procedures require that the plasmid DNA be retransformed to generate pure clones of recombinant plasmids. Therefore, a selectable marker on the incoming linear fragment is useful. Co-electroporation is preferable for ColE1-type plasmids because an already established plasmid generates multimers when Gam is expressed (26). These multimers contain both recombinant and parental segments that must be separated *in vitro* (156).

In vivo DNA Retrieval by Gap-Repair

Recombineering can be used to subclone DNA directly into a linear plasmid vector backbone without restriction enzymes or DNA ligase. Nearly any region from the bacterial chromosome, a plasmid, or a BAC clone can be retrieved into an appropriate vector. The precision of the technology allows fusions to be made between the retrieved gene and regulatory elements like promoters and translational signals on the vector.

Figure 6A describes the generation of a linear vector with ends that contain short homology segments to a target in the cell. Minimally, the vector needs a selectable drug marker and an active origin of replication. Gap-repair of the plasmid by recombination with the target circularizes the vector, allowing selection for the drug marker. Two plasmids, p15A and ColE1, with different replication origins, have worked well in gap-repair cloning (78, 160). A third plasmid, pSC101, did not generate gap-repaired recombinants in similar crosses (E. Lee & D. Court, unpublished data). Possibly the type of replicon involved determines whether linear DNA recombination can be completed. Linear DNA recombination and replication may be closely coupled events (discussed below).

The use of ColE1 plasmids presents another potential problem. High-copy, pUC-type, pBluescript vectors were used to subclone fragments up to ~25 kb, but larger fragments were much more difficult to clone. Yet, with a lower-copy pBR322 vector, fragments as large as 80-kb could be subcloned in one step (78). The high-copy vector with large inserts overtaxes the capacity of the cell for DNA synthesis.

Unwanted drug-resistant colonies can also be generated without retrieving the target in the cell. This occurs by directly joining ends via repeats longer than 5-bp, which are located at or near the end. Removal of these short repeats reduces this “end-joining” reaction dramatically (160). This type of end-joining reaction occurs rarely in normal *E. coli* strains and appears to be elevated to a higher level by the presence of the RecET and Red functions.

Earlier reports had implicated RecET function in elevating RecA-independent intrachromosomal deletions between short (~7-bp) repeats (64). The frequency of deletion formation is reduced by overexpression of the 3' to 5' exonuclease, Exo I, encoded by *xonA* (153). Likewise, a *xonA* null mutation caused an increased deletion frequency in normal cells without RecET (1). This suggests that RecE (or λ Exo) generates excess 3' ends, favoring end joining of linear vectors and intrachromosomal deletions, whereas Exo I removes 3' ends reducing end joining and intrachromosomal deletion formation. End joining may depend on annealing of 3' single-strand overhangs just as recombination mediated by RecET and Red functions does. SbcCD function in concert with single-strand annealing has also been implicated in the generation of intrachromosomal deletions through short repeats (13).

In vivo Cloning by Gap-Repair

A technology called in vivo cloning (see Figure 6B) has been used in *recBC sbcBC* mutants of *E. coli* since 1993 (12, 106) and is based on single-strand annealing. The efficiency of the procedure is enhanced dramatically by the Red and RecET systems (97). Again, a linear plasmid vector is used, but in this instance it is designed to retrieve DNA from a co-electroporated DNA fragment whose ends are homologous to the vector ends. Exo (RecE) degrades the 5'-ended strands of each co-electroporated linear DNA. Beta (RecT) binds to the ssDNA ends and anneals them to their complementary strands, where they are covalently joined by DNA ligase generating the drug-resistant plasmid clone.

A modification of the in vivo cloning protocol may allow direct cloning of a fragment from a complete genomic DNA mixture from almost any organism. This type of technology was developed in yeast where it works with homologies as short as 60-bp (77, 104). A similar technology is being developed in *E. coli* (160). Purified genomic DNA from any source is fragmented and co-electroporated with a linear vector. Homologies on the ends of the vector are used to find and retrieve the target DNA from the complex mixture in the cells. Each cell receives a portion of the genomic DNA fragments, and the complexity of the genome determines the efficiency of the retrieved target (77, 160).

RECOMBINEERING WITH ssDNA

In yeast, transformation with ssDNA has been used for recombination to generate mutations (89, 90, 154). Recent studies demonstrate that in *E. coli*, ssDNA is also recombinogenic when using λ Red (38, 142). The efficiency of recombination

with ssDNA is dramatically higher than that obtained with dsDNA. Whereas the function(s) responsible for ssDNA recombination in yeast is not known, in *E. coli* the only λ function required is Beta. Exo and Gam, required for dsDNA recombination, are not required for ssDNA. There is also no dependence on RecA for the ssDNA recombination tested (38).

The ssDNA can be supplied as synthetic oligos to make a single base change. An oligo length of 30-nt generates recombinants but a large increase is obtained with 40-nt long oligos (38). The dramatic increase in recombination efficiency between 30- and 40-nt is similar to the increase observed using flanking homologies in dsDNA (156). This critical length dependence correlates well with a length dependence of 36-nt for tight binding by Beta protein in vitro to ssDNA (62, 101). In this regard, a ssDNA oligo of 70-nt increased recombination fivefold over that for 40-, 50-, or 60-nt long oligos (38). The 70mer may provide two tight binding domains for Beta protein. Longer ssDNA oligos have also been used; a 164-nt oligo was used to introduce a 24-nt FLAG TAG sequence into a precise position in the *Brca2* mouse gene on a BAC clone (142). However, a much longer ssDNA (> 1000 nt) generated from denaturation of a PCR product with 50 nt of homology on the ends was extremely inefficient for recombination (D. Yu & D. Court, unpublished data). This may be explained by the 3' to 5' polarity of Beta binding; any nuclease that attacks the 5' end, like RecJ, could eliminate homology from that end before Beta could bind and protect it (62, 79).

In *E. coli*, ssDNA oligos have been used to create point mutations, to repair mutations, to create deletions, and to create small insertions on the chromosome and in BAC clones (38, 142). Two *galK* defects, a point mutation and a 3.3-kb insertion at the same site as the point mutation, are corrected to *galK*⁺ at the same frequency by an identical 70-nt oligo. Thus, a single base substitution and a 3.3-kb deletion were generated with equal efficiency. Other 70-nt ssDNAs have been used to cure five different *Tn10* elements from the chromosome with recombination efficiencies that reached 6% of cells surviving electroporation (38).

Recombineering with ssDNA is more efficient than with dsDNA and is the method of choice to create point mutations and other changes in a single step. Recombinants from ssDNA recombineering are so frequent that they can be screened directly from among total cells in an electroporation. In fact, a special PCR amplification screen can be used to detect the single base change of a recombinant (19, 142). In these cases, point mutations are created at frequencies approaching 1% of electroporated cells, even in the absence of RecA activity (38, 142). At these high recombination efficiencies, colony hybridization has also been used to screen for unselected recombinants, which have insertions or deletions of multiple bases (N. Costantino, L. Thomason & D. Court, unpublished data).

Recombineering with ssDNA may work in many bacterial species and even in eukaryotes under appropriate conditions, since Beta is the only λ function required and the proposed mechanism (see below) seems likely to be universal. Because this system is so simple and requires only Beta, it seemed possible that the Beta protein could be co-electroporated with ssDNA to generate recombinants not only in *E. coli*, but other organisms as well. Protein-nucleic acid co-electroporation has

worked to generate *in vivo* products with other DNA-binding proteins (45, 76). However, initial attempts to generate recombinants by co-electroporating Beta protein bound to ssDNA into *E. coli* cells have failed (H. Ellis, K. Murphy & D. Court, unpublished data).

Chromosome Recombineering with ssDNA Oligos: A Model

For any particular allele, recombinants can be generated with oligos corresponding to either of the two complementary DNA strands that include that allele. Invariably, one strand is found to recombine more frequently than the other. For markers located in different segments of the *E. coli* chromosome, the more efficient strand correlates with the direction of replication through the region being tested. In the seven cases examined, the more efficient strand corresponded to the lagging strand of DNA replication (38). This strand bias has been explained by a model in which the ssDNA oligo is annealed by Beta to the gaps present in the lagging strand as the replication fork (Figure 7) passes through the targeted region (29, 74).

The ssDNA gaps at the replication fork are coated by Ssb protein (85, 125). Therefore, Beta must either anneal the strands with Ssb still bound, or Ssb must be displaced. An Ssb displacement activity has been postulated for proteins similar to Beta (7). Since both complementary strands generate recombinants (38), ssDNA gaps may also occur in leading strand synthesis, during transcription processes, by supercoiling, and at DNA repair events. Beta may anneal the ssDNA oligos at any of these places.

RECOMBINEERING WITH dsDNA: AN INTERMEDIATE

When dsDNA is used for linear recombination, *exo*, *bet*, and *gam* gene products are required for efficient recombination (156). These results and the known biochemical properties of the Exo and Beta proteins suggested the DNA structure shown in Figure 8A. In this model, a linear dsDNA with flanking 3' ssDNA overhangs is generated as an annealing intermediate. Such a structure made *in vitro* and electroporated into a cell should be recombinogenic, and recombination should not require Exo.

Muyrers et al. (97) constructed substrates with variable length 3' overhangs flanking a drug-resistance marker. Regardless of the length of 3' overhangs, recombinants were fully dependent on Exo in addition to Beta. Even with Exo and Beta present, however, recombination efficiency was low in these experiments, perhaps because of how the substrate was constructed or because Gam was not present (97). Yu et al. (D. Yu, J. Sawitzke, H. Ellis & D. Court, manuscript in preparation) have performed similar experiments with differing results. In this case, the 3' overhangs were constructed by co-electroporating two 70-nt oligos. The oligos were such that 34-nt at the 5' ends were complementary and contained the DNA

missing within a 34-bp *galK* deletion in the recipient strain (Figure 8B). The 36-nt at each 3' end remained unpaired and were homologous to DNA flanking the 34-bp deletion. As predicted by the model, this substrate recombined and, more importantly, required only Beta. The presence or absence of Exo had no effect. This recombination was also found to be *recA* independent (D. Yu, J. Sawitzke, H. Ellis & D. Court, manuscript in preparation). Because ssDNA ends are involved, this intermediate, like ssDNA, may initiate recombination at a DNA replication fork.

Chromosome Recombineering with Linear dsDNA: A Model

A model is described in Figure 9 to account for linear dsDNA recombination using λ Red. As this recombination can be RecA independent (97, 156), we propose it occurs at the DNA replication fork. It has been suggested that recombination in the absence of RecA is catalyzed by Beta-dependent annealing (139, 140) of complementary 3' ssDNA. In this way, the dsDNA intermediate (Figure 8A) anneals at the fork and triggers a block to fork progression (32). As drawn, this structure looks like a precursor to a four-way Holliday junction (Figure 9A). Stalled DNA replication forks are known to backtrack (32). During backtracking (Figure 9B), the leading strand is transferred and annealed to the 3' ssDNA of the dsDNA intermediate to create a chicken foot-like structure (53, 110). DNA polymerase I (PolA) can initiate repair synthesis on the backtracked leading strand (Figure 9C), using the dsDNA intermediate as a template; DNA ligase can then covalently join the leading strand to the intermediate. The replication fork is reestablished by branch migration as shown in Figure 9D such that each strand of the original linear dsDNA intermediate forms the new strand at the regenerated replication fork.

Blocking Branch Migration by a Large Nonhomologous Region: A Modified Model

RecA-independent recombination can occur between the chromosome and linear DNA containing a nonhomologous cassette flanked by homologies to the target (156). We propose that with these substrates the 3' single-strand end of the linear duplex also anneals at the replication fork and generates the same intermediates as described in Figure 9C. However, branch migration, like that in Figure 9D, is blocked by the large nonhomology of the *cat* cassette (Figure 10A) stalling the replication fork and preventing completion of the recombination event. However, both processes can be rescued by the second *E. coli* replication fork that traverses the chromosome in the opposite direction (Figure 10A). The second fork must pass through the *E. coli* terminus and proceed to the stalled fork. It is not clear how long this would take or how efficient it is. Preliminary studies indicate that other λ functions in the *p_L* operon prevent new rounds of DNA replication from initiating (K. Surgueev, D. Court & S. Austin, submitted). Once at the stalled

fork, the second fork can provide an annealing site that is complementary to the 3' single-strand at the other side of the drug cassette. These two single-strand regions can be annealed by Beta, and as described in Figure 9C, PolA catalyzes replication, and DNA ligase can then repair the leading strand gap joining it to the *cat* cassette (Figure 10B). The daughter chromosomes remain linked at the *cat* cassette and resolution of the junctions will presumably require RuvC (127) or perhaps a topoisomerase (158). The end result is that two chromosomes are generated, a parental and recombinant with the cassette replacement.

RECOMBINEERING: TAPPING ITS POTENTIAL

Currently, the phage-encoded requirements for recombineering are well defined and the process is very efficient even in *recA* mutant cells; however, other host requirements have not been determined. Our models that describe Red-mediated recombination at the replication fork suggest candidate functions that act during DNA replication. Replication functions associated with λ Red-mediated processes are DNA polymerase I and DNA ligase. Phage λ growth in *lig* or *polA* mutants is defective in the absence of *exo*, *bet*, or *gam* (134, 137), indicating the interactions of these functions.

Recombineering is so efficient that it can provide the substrates for in vivo biochemistry. For example, insertion of modified nucleotides (biotinylated, fluorescent, phosphothiolated, etc.) directly into the chromosome can be used to study the processes of DNA replication, recombination, and chromosome segregation. One potential use of such modified nucleotides is to identify the site of Red-mediated recombination in the cell and the structure of the DNA at that site. For example, a biotin tag could be used to isolate a fragment of the chromosome containing recombination intermediates to help determine their structure.

Although recombineering in *E. coli* has been studied for only four years, it is being used by large numbers of researchers in both prokaryotic and eukaryotic applications. Using oligo mutagenesis, any base on the chromosome can be changed in one step without selection. With appropriate controls, it should be possible to determine which changes affect viability of the cell. Because the recombineering technology is well defined, it may be possible to adapt it to other organisms (117, 124). In organisms where Red is not active, analogs that can carry out the same functions will undoubtedly be found in the viruses of these organisms, be they prokaryotic or eukaryotic.

ACKNOWLEDGMENTS

We thank Nina Costantino, David Friedman, and Carolyn McGill for critical reading and discussion of the manuscript. We thank Marg Mills for preparing the manuscript and editorial comments. We also thank Daiguan Yu, Hillary Ellis, and E-Chiang Lee for stimulating discussions on these subjects.

The Annual Review of Genetics is online at <http://genet.annualreviews.org>

LITERATURE CITED

1. Allgood ND, Silhavy TJ. 1991. *Escherichia coli xonA (sbcB)* mutants enhance illegitimate recombination. *Genetics* 127: 671–80
2. Amundsen SK, Taylor AF, Smith GR. 2000. The RecD subunit of the *Escherichia coli* RecBCD enzyme inhibits RecA loading, homologous recombination, and DNA repair. *Proc. Natl. Acad. Sci. USA* 97:7399–404
3. Anderson DG, Kowalczykowski SC. 1997. The translocating RecBCD enzyme stimulates recombination by directing RecA protein onto ssDNA in a chiral manner. *Cell* 90:77–86
4. Asai T, Bates DB, Kogoma T. 1994. DNA replication triggered by double-stranded breaks in *E. coli*: dependence on homologous recombination functions. *Cell* 78:1051–61
5. Barbour SD, Nagaishi H, Templin A, Clark AJ. 1970. Biochemical and genetic studies of recombination proficiency in *Escherichia coli*. II. Rec⁺ revertants caused by indirect suppression of rec⁻ mutations. *Proc. Natl. Acad. Sci. USA* 67: 128–35
6. Baudin A, Ozier-Kalogeropoulos O, Denouel A, Lacroute F, Cullin C. 1993. A simple and efficient method for direct gene deletion in *Saccharomyces cerevisiae*. *Nucleic Acids Res.* 21:3329–30
7. Beernink HT, Morrical SW. 1999. RMPs: recombination/replication mediator proteins. *Trends Biochem. Sci.* 24:385–89
8. Benzinger R, Enquist LW, Skalka A. 1975. Transfection of *Escherichia coli* spheroplasts. V. Activity of RecBC nuclease in rec⁺ and rec⁻ spheroplasts measured with different forms of bacteriophage DNA. *J. Virol.* 15:861–71
9. Brcic-Kostic K, Stojiljkovic I, Salajsmic E, Trgovcevic Z. 1989. The recB gene product is essential for exonuclease V-dependent DNA degradation *in vivo*. *Mutat. Res.* 227:247–50
10. Brooks K, Clark AJ. 1967. Behavior of λ bacteriophage in a recombination-deficient strain of *Escherichia coli*. *J. Virol.* 1:283–93
11. Brune W, Messerle M, Koszinowski UH. 2000. Forward with BACs: new tools for herpesvirus genomics. *Trends Genet.* 16:254–59
12. Bubeck P, Winkler M, Bautsch W. 1993. Rapid cloning by homologous recombination *in vivo*. *Nucleic Acids Res.* 21:3601–2
13. Bzymek M, Lovett ST. 2001. Evidence for two mechanisms of palindrome-stimulated deletion in *Escherichia coli*: single-strand annealing and replication slipped mispairing. *Genetics* 158:527–40
14. Campbell A. 1984. Types of recombination: common problems and common strategies. *Cold Spring Harb. Symp. Quant. Biol.* 49:839–44
15. Capaldo FN, Barbour SD. 1975. The role of the rec genes in the viability of *Escherichia coli* K12. *Basic Life Sci.* 5A:405–18
16. Carter DM, Radding CM. 1971. The role of exonuclease and β protein of phage λ in genetic recombination. II. Substrate specificity and the mode of action of lambda exonuclease. *J. Biol. Chem.* 246:2502–12
17. Cassuto E, Lash T, Sriprakash KS, Radding CM. 1971. Role of exonuclease and β protein of phage λ in genetic recombination. V. Recombination of λ DNA *in vitro*. *Proc. Natl. Acad. Sci. USA* 68:1639–43
18. Cassuto E, Radding CM. 1971. Mechanism for the action of λ exonuclease in genetic recombination. *Nat. New Biol.* 229:13–16
19. Cha RS, Zarbl H, Keohavong P, Thilly WG. 1992. Mismatch amplification mutation assay (MAMA): application to the

- c-H-ras gene. *PCR Methods Appl.* 2:14–20
20. Chalker AF, Leach DR, Lloyd RG. 1988. *Escherichia coli sbcC* mutants permit stable propagation of DNA replicons containing a long palindrome. *Gene* 71:201–5
 21. Churchill JJ, Anderson DG, Kowalczykowski SC. 1999. The RecBC enzyme loads RecA protein onto ssDNA asymmetrically and independently of chi, resulting in constitutive recombination activation. *Genes Dev.* 13:901–11
 22. Clark AJ. 1973. Recombination deficient mutants of *E. coli* and other bacteria. *Annu. Rev. Genet.* 7:67–86
 23. Clark AJ. 1991. *rec* genes and homologous recombination proteins in *Escherichia coli*. *Biochimie* 73:523–32
 24. Clark AJ, Margulies AD. 1965. Isolation and characterization of recombination-deficient mutants of *Escherichia coli* K12. *Proc. Natl. Acad. Sci. USA* 53:451–59
 25. Clark AJ, Sandler SJ. 1994. Homologous genetic recombination: the pieces begin to fall into place. *Crit. Rev. Microbiol.* 20:125–42
 26. Cohen A, Clark AJ. 1986. Synthesis of linear plasmid multimers in *Escherichia coli* K-12. *J. Bacteriol.* 167:327–35
 27. Connelly JC, de Leau ES, Leach DR. 1999. DNA cleavage and degradation by the SbcCD protein complex from *Escherichia coli*. *Nucleic Acids Res.* 27:1039–46
 28. Connelly JC, Kirkham LA, Leach DR. 1998. The SbcCD nuclease of *Escherichia coli* is a structural maintenance of chromosomes (SMC) family protein that cleaves hairpin DNA. *Proc. Natl. Acad. Sci. USA* 95:7969–74
 29. Copeland NG, Jenkins NA, Court DL. 2001. Recombineering: a powerful new tool for mouse functional genomics. *Nat. Rev. Genet.* 2:769–79
 30. Courcelle J, Hanawalt PC. 1999. RecQ and RecJ process blocked replication forks prior to the resumption of replication in UV-irradiated *Escherichia coli*. *Mol. Gen. Genet.* 262:543–51
 31. Court D, Oppenheim AB. 1983. Phage lambda's accessory genes. See Ref. 51a, pp. 251–77
 32. Cox MM. 2001. Recombinational DNA repair of damaged replication forks in *Escherichia coli*: questions. *Annu. Rev. Genet.* 35:53–82
 33. Cromie GA, Millar CB, Schmidt KH, Leach DR. 2000. Palindromes as substrates for multiple pathways of recombination in *Escherichia coli*. *Genetics* 154:513–22
 34. Dabert P, Smith GR. 1997. Gene replacement with linear DNA fragments in wild-type *Escherichia coli*: enhancement by Chi sites. *Genetics* 145:877–89
 35. Datsenko KA, Wanner BL. 2000. One-step inactivation of chromosomal genes in *Escherichia coli* K-12 using PCR products. *Proc. Natl. Acad. Sci. USA* 97:6640–45
 36. Echols H, Gingery R. 1968. Mutants of bacteriophage λ defective in vegetative genetic recombination. *J. Mol. Biol.* 34:239–49
 37. El Karoui M, Amundsen SK, Dabert P, Gruss A. 1999. Gene replacement with linear DNA in electroporated wild-type *Escherichia coli*. *Nucleic Acids Res.* 27:1296–99
 38. Ellis HM, Yu D, DiTizio T, Court DL. 2001. High efficiency mutagenesis, repair, and engineering of chromosomal DNA using single-stranded oligonucleotides. *Proc. Natl. Acad. Sci. USA* 98:6742–46
 39. Emmerson PT. 1968. Recombination deficient mutants of *Escherichia coli* K12 that map between *thyA* and *argA*. *Genetics* 60:19–30
 40. Feiss M, Siegele DA, Rudolph CF, Frackman S. 1982. Cosmid DNA packaging in vivo. *Gene* 17:123–30
 41. Franklin NC. 1967. Extraordinary recombinational events in *Escherichia coli*. Their independence of the *rec*⁺ function. *Genetics* 55:699–707

42. Friedman SA, Hays JB. 1986. Selective inhibition of *Escherichia coli* *recBC* activities by plasmid-encoded GamS function of phage λ . *Gene* 43:255–63
43. Gay P, Le Coq D, Steinmetz M, Ferrari E, Hoch JA. 1983. Cloning structural gene *sacB*, which codes for exoenzyme levansucrase of *Bacillus subtilis*: expression of the gene in *Escherichia coli*. *J. Bacteriol.* 153:1424–31
44. Gibson FP, Leach DRF, Lloyd RG. 1992. Identification of *sbcD* mutations as cosuppressors of *recBC* that allow propagation of DNA palindromes in *Escherichia coli* K-12. *J. Bacteriol.* 174:1222–28
45. Goryshin IY, Jendrisak J, Hoffman LM, Meis R, Reznikoff WS. 2000. Insertional transposon mutagenesis by electroporation of released *Tn5* transposition complexes. *Nat. Biotechnol.* 18:97–100
46. Gottesman ME, Yarmolinsky MB. 1968. Integration-negative mutants of bacteriophage λ . *J. Mol. Biol.* 31:487–505
47. Gottesman MM, Gottesman ME, Gottesman S, Gellert M. 1974. Characterization of bacteriophage λ reverse as an *Escherichia coli* phage carrying a unique set of host-derived recombination functions. *J. Mol. Biol.* 88:471–87
48. Hall SD, Kane MF, Kolodner RD. 1993. Identification and characterization of the *Escherichia coli* RecT protein, a protein encoded by the *recE* region that promotes renaturation of homologous single-stranded DNA. *J. Bacteriol.* 175:277–87
49. Hall SD, Kolodner RD. 1994. Homologous pairing and strand exchange promoted by the *Escherichia coli* RecT protein. *Proc. Natl. Acad. Sci. USA* 91:3205–9
50. Hamilton CM, Aldea M, Washburn BK, Babitzke P, Kushner SR. 1989. New method for generating deletions and gene replacements in *Escherichia coli*. *J. Bacteriol.* 171:4617–22
51. Hays JB, Smith TA, Friedman SA, Lee E, Coffman GL. 1984. RecF and RecBC function during recombination of non-replicating, UV-irradiated phage λ DNA and during other recombination processes. *Cold Spring Harb. Symp. Quant. Biol.* 49:475–83
- 51a. Hendrix RW, Roberts JW, Stahl FW, Weisberg RA, eds. 1983. *Lambda II*. Cold Spring Harbor, NY: Cold Spring Harbor Lab.
52. Henry MF, Cronan JE Jr. 1991. Direct and general selection for lysogens of *Escherichia coli* by phage λ recombinant clones. *J. Bacteriol.* 173:3724–31
53. Higgins NP, Kato K, Strauss B. 1976. A model for replication repair in mammalian cells. *J. Mol. Biol.* 101:417–25
54. Hill F, Benes V, Thomasova D, Stewart AF, Kafatos FC, Ansoorge W. 2000. BAC trimming: minimizing clone overlaps. *Genomics* 64:111–13
55. Hill SA, Stahl MM, Stahl FW. 1997. Single-strand DNA intermediates in phage λ 's Red recombination pathway. *Proc. Natl. Acad. Sci. USA* 94:2951–56
56. Horii Z, Clark AJ. 1973. Genetic analysis of the RecF pathway to genetic recombination in *Escherichia coli* K12: isolation and characterization of mutants. *J. Mol. Biol.* 80:327–44
57. Horiuchi T, Fujimura Y. 1995. Recombinational rescue of the stalled DNA replication fork: a model based on analysis of an *Escherichia coli* strain with a chromosome region difficult to replicate. *J. Bacteriol.* 177:783–91
58. Ioannou PA, Amemiya CT, Garnes J, Kroisel PM, Shizuya H, et al. 1994. A new bacteriophage P1-derived vector for the propagation of large human DNA fragments. *Nat. Genet.* 6:84–89
59. Jasin M, Schimmel P. 1984. Deletion of an essential gene in *Escherichia coli* by site-specific recombination with linear DNA fragments. *J. Bacteriol.* 159:783–86
60. Joseph JW, Kolodner R. 1983. Exonuclease VIII of *Escherichia coli*. I. Purification and physical properties. *J. Biol. Chem.* 258:10411–17

61. Joseph JW, Kolodner R. 1983. Exonuclease VIII of *Escherichia coli*. II. Mechanism of action. *J. Biol. Chem.* 258:10418–24
62. Karakousis G, Ye N, Li Z, Chiu SK, Reddy G, Radding CM. 1998. The β protein of phage λ binds preferentially to an intermediate in DNA renaturation. *J. Mol. Biol.* 276:721–31
63. Karu AE, Sakaki Y, Echols H, Linn S. 1975. The gamma protein specified by bacteriophage λ . Structure and inhibitory activity for the RecBC enzyme of *Escherichia coli*. *J. Biol. Chem.* 250:7377–87
64. Keim P, Lark KG. 1990. The RecE recombination pathway mediates recombination between partially homologous DNA sequences: structural analysis of recombination products. *J. Struct. Biol.* 104:97–106
65. Kmiec E, Holloman WK. 1981. β protein of bacteriophage λ promotes renaturation of DNA. *J. Biol. Chem.* 256:12636–39
66. Kogoma T. 1997. Stable DNA replication: interplay between DNA replication, homologous recombination, and transcription. *Microbiol. Mol. Biol. Rev.* 61:212–38
67. Kohara Y, Akiyama K, Isono K. 1987. The physical map of the whole *E. coli* chromosome: application of a new strategy for rapid analysis and sorting of a large genomic library. *Cell* 50:495–508
68. Kovall R, Matthews BW. 1997. Toroidal structure of lambda-exonuclease. *Science* 277:1824–27
69. Kowalczykowski SC. 2000. Initiation of genetic recombination and recombination-dependent replication. *Trends Biochem. Sci.* 25:156–65
70. Kulkarni SK, Stahl FW. 1989. Interaction between the *sbcC* gene of *Escherichia coli* and the *gam* gene of phage λ . *Genetics* 123:249–53
71. Kusano K, Sunohara Y, Takahashi N, Yoshikura H, Kobayashi I. 1994. DNA double-strand break repair: genetic determinants of flanking crossing-over. *Proc. Natl. Acad. Sci. USA* 91:1173–77
72. Kushner SR, Nagaishi H, Clark AJ. 1972. Indirect suppression of *recB* and *recC* mutations by exonuclease I deficiency. *Proc. Natl. Acad. Sci. USA* 69:1366–70
73. Kuzminov A. 1995. Collapse and repair of replication forks in *Escherichia coli*. *Mol. Microbiol.* 16:373–84
74. Kuzminov A. 1999. Recombinational repair of DNA damage in *Escherichia coli* and bacteriophage λ . *Microbiol. Mol. Biol. Rev.* 63:751–813
75. Lafontaine D, Tollervey D. 1996. One-step PCR mediated strategy for the construction of conditionally expressed and epitope tagged yeast proteins. *Nucleic Acids Res.* 24:3469–71
76. Lamberg A, Nieminen S, Qiao M, Savilahti H. 2002. Efficient insertion mutagenesis strategy for bacterial genomes involving electroporation of *in vitro*-assembled DNA transposition complexes of bacteriophage μ . *Appl. Environ. Microbiol.* 68:705–12
77. Larionov V. 1999. Direct isolation of specific chromosomal regions and entire genes by TAR cloning. *Genet. Eng.* 21:37–55
78. Lee EC, Yu D, Martinez de Velasco J, Tesarollo L, Swing DA, et al. 2001. A highly efficient *Escherichia coli*-based chromosome engineering system adapted for recombinogenic targeting and subcloning of BAC DNA. *Genomics* 73:56–65
79. Li Z, Karakousis G, Chiu SK, Reddy G, Radding CM. 1998. The β protein of phage λ promotes strand exchange. *J. Mol. Biol.* 276:733–44
80. Little JW. 1967. An exonuclease induced by bacteriophage λ . II. Nature of the enzymatic reaction. *J. Biol. Chem.* 242:679–86
81. Lloyd RG, Buckman C. 1985. Identification and genetic analysis of *sbcC* mutations in commonly used *recBC sbcB* strains of *Escherichia coli* K-12. *J. Bacteriol.* 164:836–44
82. Lovett ST, Kolodner RD. 1989. Identification and purification of a single-stranded-DNA-specific exonuclease encoded by the

- recJ* gene of *Escherichia coli*. *Proc. Natl. Acad. Sci. USA* 86:2627–31
83. Luisi-DeLuca C, Kolodner RD. 1992. Effect of terminal non-homology on intramolecular recombination of linear plasmid substrates in *Escherichia coli*. *J. Mol. Biol.* 227:72–80
 84. Manly KF, Signer ER, Radding CM. 1969. Nonessential functions of bacteriophage λ . *Virology* 37:177–88
 85. Marians KJ. 1996. Replication fork propagation. In *Escherichia coli and Salmonella*, ed. FC Neidhardt, R Curtiss III, JL Ingraham, ECC Lin, KB Low, et al., pp. 749–63. Washington, DC: ASM Press
 86. Marinus MG, Carraway M, Frey AZ, Brown L, Arraj JA. 1983. Insertion mutations in the *dam* gene of *Escherichia coli* K-12. *Mol. Gen. Genet.* 192:288–89
 87. Marsic N, Roje S, Stojiljkovic I, Salajsmic E, Trgovcevic Z. 1993. In vivo studies on the interaction of RecBCD enzyme and λ Gam protein. *J. Bacteriol.* 175:4738–43
 88. Matsuura S, Komatsu J, Hirano K, Yasuda H, Takashima K, et al. 2001. Real-time observation of a single DNA digestion by λ exonuclease under a fluorescence microscope field. *Nucleic Acids Res.* 29:E79
 89. Moerschell RP, Das G, Sherman F. 1991. Transformation of yeast directly with synthetic oligonucleotides. *Methods Enzymol.* 194:362–69
 90. Moerschell RP, Tsunasawa S, Sherman F. 1988. Transformation of yeast with synthetic oligonucleotides. *Proc. Natl. Acad. Sci. USA* 85:524–28
 91. Muniyappa K, Mythili E. 1993. Phage $\lambda\beta$ protein, a component of general recombination, is associated with host ribosomal S1 protein. *Biochem. Mol. Biol. Int.* 31:1–11
 92. Muniyappa K, Radding CM. 1986. The homologous recombination system of phage λ . Pairing activities of β protein. *J. Biol. Chem.* 261:7472–78
 93. Murphy KC. 1991. λ Gam protein inhibits the helicase and chi-stimulated recombination activities of *Escherichia coli* RecBCD enzyme. *J. Bacteriol.* 173:5808–21
 94. Murphy KC. 1998. Use of bacteriophage λ recombination functions to promote gene replacement in *Escherichia coli*. *J. Bacteriol.* 180:2063–71
 95. Murphy KC, Campellone KG, Poteete AR. 2000. PCR-mediated gene replacement in *Escherichia coli*. *Gene* 246:321–30
 96. Muyrers JP, Zhang Y, Benes V, Testa G, Ansoerge W, Stewart AF. 2000. Point mutation of bacterial artificial chromosomes by ET recombination. *EMBO Rep.* 1:239–43
 97. Muyrers JP, Zhang Y, Buchholz F, Stewart AF. 2000. RecE/RecT and Red α /Red β initiate double-stranded break repair by specifically interacting with their respective partners. *Genes Dev.* 14:1971–82
 98. Muyrers JP, Zhang Y, Stewart AF. 2001. Techniques: recombinogenic engineering—new options for cloning and manipulating DNA. *Trends Biochem. Sci.* 26:325–31
 99. Muyrers JP, Zhang Y, Testa G, Stewart AF. 1999. Rapid modification of bacterial artificial chromosomes by ET-recombination. *Nucleic Acids Res.* 27:1555–57
 100. Myers RS, Stahl FW. 1994. Chi and the RecBCD enzyme of *Escherichia coli*. *Annu. Rev. Genet.* 28:49–70
 101. Mythili E, Kumar KA, Muniyappa K. 1996. Characterization of the DNA-binding domain of β protein, a component of phage λ Red-pathway, by UV catalyzed cross-linking. *Gene* 182:81–87
 102. Naom IS, Morton SJ, Leach DR, Lloyd RG. 1989. Molecular organization of *sbC*, a gene that affects genetic recombination and the viability of DNA palindromes in *Escherichia coli* K-12. *Nucleic Acids Res.* 17:8033–45
 103. Noirot P, Kolodner RD. 1998. DNA strand invasion promoted by *Escherichia coli* RecT protein. *J. Biol. Chem.* 273:12274–80

104. Noskov VN, Koriabine M, Solomon G, Randolph M, Barrett JC, et al. 2001. Defining the minimal length of sequence homology required for selective gene isolation by TAR cloning. *Nucleic Acids Res.* 29:E32
105. O'Connor M, Peifer M, Bender W. 1989. Construction of large DNA segments in *Escherichia coli*. *Science* 244:1307–12
106. Oliner JD, Kinzler KW, Vogelstein B. 1993. In vivo cloning of PCR products in *E. coli*. *Nucleic Acids Res.* 21:5192–97
107. Orr-Weaver TL, Szostak JW, Rothstein RJ. 1981. Yeast transformation: a model system for the study of recombination. *Proc. Natl. Acad. Sci. USA* 78:6354–58
108. Paskvan I, Salaj-Smic E, Ivancic-Bace I, Zahradka K, Trgovcevic Z, Brcic-Kostic K. 2001. The genetic dependence of RecBCD-Gam mediated double strand end repair in *Escherichia coli*. *FEMS Microbiol. Lett.* 205:299–303
109. Passy SI, Yu X, Li Z, Radding CM, Egelman EH. 1999. Rings and filaments of β protein from bacteriophage λ suggest a superfamily of recombination proteins. *Proc. Natl. Acad. Sci. USA* 96:4279–84
110. Postow L, Crisona NJ, Peter BJ, Hardy CD, Cozzarelli NR. 2001. Topological challenges to DNA replication: conformations at the fork. *Proc. Natl. Acad. Sci. USA* 98:8219–26
111. Poteete AR. 2001. What makes the bacteriophage λ Red system useful for genetic engineering: molecular mechanism and biological function. *FEMS Microbiol. Lett.* 201:9–14
112. Poteete AR, Fenton AC. 1993. Efficient double-strand break-stimulated recombination promoted by the general recombination systems of phages λ and P22. *Genetics* 134:1013–21
113. Poteete AR, Fenton AC. 2000. Genetic requirements of phage λ Red-mediated gene replacement in *Escherichia coli* K-12. *J. Bacteriol.* 182:2336–40
114. Poteete AR, Fenton AC, Murphy KC. 1988. Modulation of *Escherichia coli* RecBCD activity by the bacteriophage λ Gam and P22 Abc functions. *J. Bacteriol.* 170:2012–21
115. Poteete AR, Fenton AC, Murphy KC. 1999. Roles of RuvC and RecG in phage λ Red-mediated recombination. *J. Bacteriol.* 181:5402–8
116. Poteete AR, Volkert MR. 1988. Activation of RecF-dependent recombination in *Escherichia coli* by bacteriophage λ and P22-encoded functions. *J. Bacteriol.* 170:4379–81
117. Price-Carter M, Tingey J, Bobik TA, Roth JR. 2001. The alternative electron acceptor tetrathionate supports B12-dependent anaerobic growth of *Salmonella enterica* serovar typhimurium on ethanolamine or 1,2-propanediol. *J. Bacteriol.* 183:2463–75
118. Radding CM, Rosenzweig J, Richards F, Cassuto E. 1971. Separation and characterization of exonuclease, β protein, and a complex of both. *J. Biol. Chem.* 246:2510–12
119. Raibaud O, Mock M, Schwartz M. 1984. A technique for integrating any DNA fragment into the chromosome of *Escherichia coli*. *Gene* 29:231–41
120. Roca AI, Cox MM. 1997. RecA protein: structure, function, and role in recombinational DNA repair. *Prog. Nucleic Acid Res. Mol. Biol.* 56:129–223
121. Russell CB, Thaler DS, Dahlquist FW. 1989. Chromosomal transformation of *Escherichia coli* recD strains with linearized plasmids. *J. Bacteriol.* 171:2609–13
122. Salaj-Smic E, Dermic D, Brcic-Kostic K, Cajo GC, Trgovcevic E. 2000. In vivo studies of the *Escherichia coli* RecB polypeptide lacking its nuclease center. *Res. Microbiol.* 151:769–76
123. Sandler SJ, Marians KJ. 2000. Role of PriA in replication fork reactivation in *Escherichia coli*. *J. Bacteriol.* 182:9–13
124. Scheirer KE, Higgins NP. 2001. Transcription induces a supercoil domain barrier in bacteriophage Mu. *Biochimie* 83:155–59

125. Sekimizu K, Bramhill D, Kornberg A. 1988. Sequential early stages in the in vitro initiation of replication at the origin of the *Escherichia coli* chromosome. *J. Biol. Chem.* 263:7124–30
126. Sergueev K, Yu D, Austin S, Court D. 2001. Cell toxicity caused by products of the p_L operon of bacteriophage lambda. *Gene* 272:227–35
127. Sharples GJ, Ingleston SM, Lloyd RG. 1999. Holliday junction processing in bacteria: insights from the evolutionary conservation of RuvABC, RecG, and RuvA. *J. Bacteriol.* 181:5543–50
128. Shizuya H, Birren B, Kim UJ, Mancino V, Slepak T, et al. 1992. Cloning and stable maintenance of 300-kilobase-pair fragments of human DNA in *Escherichia coli* using an F-factor-based vector. *Proc. Natl. Acad. Sci. USA* 89:8794–97
129. Shulman MJ, Hallick LM, Echols H, Signer ER. 1970. Properties of recombination-deficient mutants of bacteriophage λ . *J. Mol. Biol.* 52:501–20
130. Signer ER, Weil J. 1968. Recombination in bacteriophage λ . I. Mutants deficient in general recombination. *J. Mol. Biol.* 34:261–71
131. Silberstein Z, Cohen A. 1987. Synthesis of linear multimers of OriC and pBR322 derivatives in *Escherichia coli* K-12: role of recombination and replication functions. *J. Bacteriol.* 169:3131–37
132. Silberstein Z, Maor S, Berger I, Cohen A. 1990. λ Red-mediated synthesis of plasmid linear multimers in *Escherichia coli* K12. *Mol. Gen. Genet.* 223:496–507
133. Silberstein Z, Tzfati Y, Cohen A. 1995. Primary products of break-induced recombination by *Escherichia coli* RecE pathway. *J. Bacteriol.* 177:1692–98
134. Skalka A. 1974. A replicator's view of recombination (and repair). In *Mechanisms in Recombination*, ed. RF Grell, pp. 421–32. New York: Plenum
135. Skalka AM. 1977. DNA replication—bacteriophage λ . *Curr. Top. Microbiol. Immunol.* 78:201–37
136. Slater S, Maurer R. 1993. Simple phagemid-based system for generating allele replacements in *Escherichia coli*. *J. Bacteriol.* 175:4260–62
137. Smith GR. 1983. General recombination. See Ref. 51a, pp. 175–209
138. Sriprakash KS, Lundh N, Huh M-O, Radding CM. 1975. The specificity of λ exonuclease. Interactions with single-stranded DNA. *J. Biol. Chem.* 250:5438–45
139. Stahl FW. 1998. Recombination in phage λ : one geneticist's historical perspective. *Gene* 223:95–102
140. Stahl MM, Thomason L, Poteete AR, Tarkowski T, Kuzminov A, Stahl FW. 1997. Annealing vs. invasion in phage λ recombination. *Genetics* 147:961–77
141. Sternberg NL. 1992. Cloning high molecular weight DNA fragments by the bacteriophage P1 system. *Trends Genet.* 8:11–16
142. Swaminathan S, Ellis HM, Waters LS, Yu D, Lee E-C, et al. 2001. Rapid engineering of bacterial artificial chromosomes using oligonucleotides. *Genesis* 29:14–21
143. Szostak JW, Orr WT, Rothstein RJ, Stahl FW. 1983. The double-strand-break repair model for recombination. *Cell* 33:25–35
144. Takahashi NK, Kusano K, Yokochi T, Kitamura Y, Yoshikura H, Kobayashi I. 1993. Genetic analysis of double-strand break repair in *Escherichia coli*. *J. Bacteriol.* 175:5176–85
145. Taylor A, Smith GR. 1980. Unwinding and rewinding of DNA by the RecBC enzyme. *Cell* 22:447–57
146. Trogovcevic Z, Rupp WD. 1975. Lambda bacteriophage gene products and X-ray sensitivity of *Escherichia coli*: comparison of *red*-dependent and *gam*-dependent radioresistance. *J. Bacteriol.* 123:212–21
147. Umezumi K, Chi N-W, Kolodner RD. 1993. Biochemical interaction of the *Escherichia coli* RecF, RecO, and RecR proteins with RecA protein and single-stranded DNA binding protein. *Proc. Natl. Acad. Sci. USA* 90:3875–79

148. Unger RC, Clark AJ. 1972. Interaction of the recombination pathways of bacteriophage λ and its host *Escherichia coli* K12: effects on exonuclease V activity. *J. Mol. Biol.* 70:539–48
149. Uzzau S, Figueroa-Bossi N, Rubino S, Bossi L. 2001. Epitope tagging of chromosomal genes in Salmonella. *Proc. Natl. Acad. Sci. USA* 98:15264–69
150. van Oostrum J, White JL, Burnett RM. 1985. Isolation and crystallization of λ exonuclease. *Arch. Biochem. Biophys.* 243:332–37
151. Venkatesh TV, Radding CM. 1993. Ribosomal protein S1 and NusA protein complexed to recombination protein β of phage λ . *J. Bacteriol.* 175:1844–46
152. Winans SC, Elledge SJ, Krueger JH, Walker GC. 1985. Site-directed insertion and deletion mutagenesis with cloned fragments in *Escherichia coli*. *J. Bacteriol.* 161:1219–21
153. Yamaguchi H, Hanada K, Asami Y, Kato JI, Ikeda H. 2000. Control of genetic stability in *Escherichia coli*: the SbcB 3'-5' exonuclease suppresses illegitimate recombination promoted by the RecE 5'-3' exonuclease. *Genes Cells* 5:101–9
154. Yamamoto T, Moerschell RP, Wakem LP, Ferguson D, Sherman F. 1992. Parameters affecting the frequencies of transformation and co-transformation with synthetic oligonucleotides in yeast. *Yeast* 8:935–48
155. Yang XW, Model P, Heintz N. 1997. Homologous recombination based modification in *Escherichia coli* and germline transmission in transgenic mice of a bacterial artificial chromosome. *Nat. Biotechnol.* 15:859–65
156. Yu D, Ellis HM, Lee EC, Jenkins NA, Copeland NG, Court DL. 2000. An efficient recombination system for chromosome engineering in *Escherichia coli*. *Proc. Natl. Acad. Sci. USA* 97:5978–83
157. Zagursky RJ, Hays JB. 1983. Expression of the phage λ recombination genes *exo* and *bet* under *lacPO* control on a multicopy plasmid. *Gene* 23:277–92
158. Zechiedrich EL, Cozzarelli NR. 1995. Roles of topoisomerase IV and DNA gyrase in DNA unlinking during replication in *Escherichia coli*. *Genes Dev.* 9:2859–69
159. Zhang Y, Buchholz F, Muyrers JP, Stewart AF. 1998. A new logic for DNA engineering using recombination in *Escherichia coli*. *Nat. Genet.* 20:123–28
160. Zhang Y, Muyrers JP, Testa G, Stewart AF. 2000. DNA cloning by homologous recombination in *Escherichia coli*. *Nat. Biotechnol.* 18:1314–17
161. Zissler J, Signer E, Schaefer F. 1971. The role of recombination in growth of bacteriophage λ . I. The *gamma* gene. In *The Bacteriophage Lambda*, ed. AD Hershey, pp. 455–68. Cold Spring Harbor, NY: Cold Spring Harbor Lab.

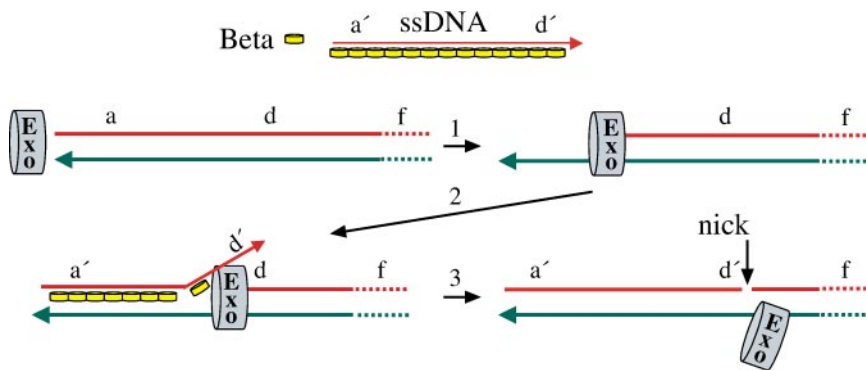

Figure 3 Single-strand annealing and assimilation by λ Exo and Beta. Exo is shown loading at the end of a DNA molecule. Arrows labeled 1, 2, 3 represent the progression of events. A ssDNA is shown bound with Beta protein before annealing and as it anneals to a ssDNA overhang. Exo falls off as annealing is completed to generate a nick in the DNA.

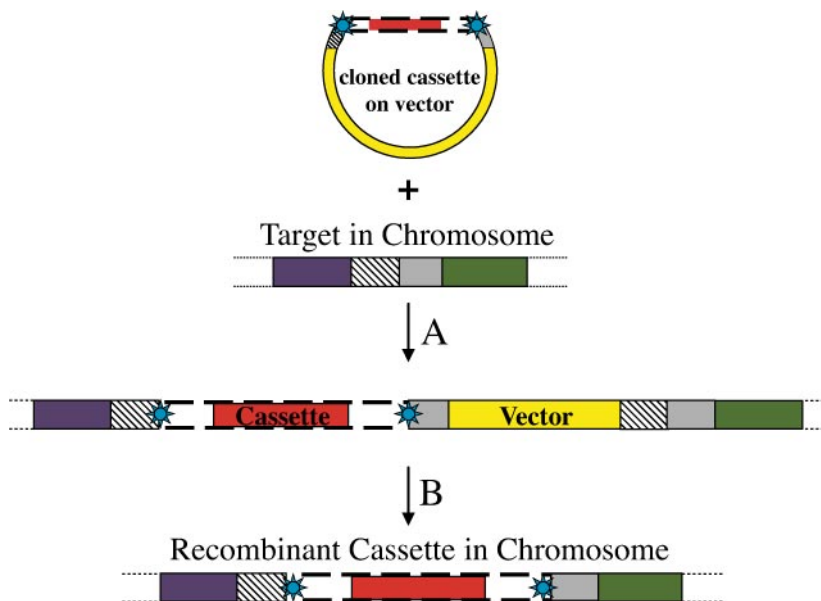

Figure 4 Homologous recombination-mediated insertion and excision of vector DNA for allelic replacement. A DNA cassette (red) is cloned into a vector (yellow) between two DNA segments that have homologies to target sites in the bacterial chromosome. Stars represent restriction sites. The homologies are represented by striped and gray boxes on the vector and chromosome. Insertion (A) occurs by RecA-mediated recombination between the striped homology segment on the chromosome and vector. Excision (B) of the vector leaves behind the cassette as the product of a second recombination between the gray segments. The vector described here could be either a phage λ or a plasmid that is conditionally defective for replication.

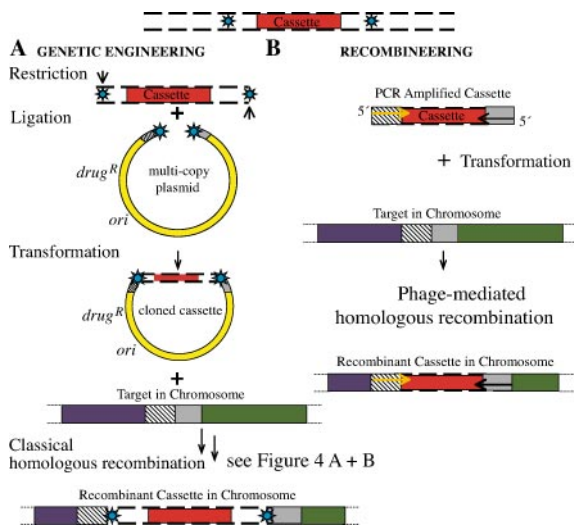

Figure 5 A comparison of steps required to create a recombinant DNA in the chromosome using standard genetic engineering (A) or recombinering (B). The cassette is indicated in its native site at the top flanked by restriction sites (stars). Figure 4 describes other details of the figure. The horizontal arrows in part B indicate the primers used to PCR amplify the cassette with flanking homologies.

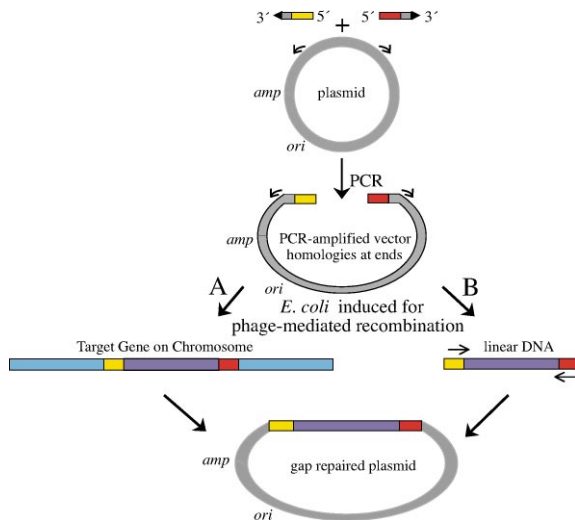

Figure 6 Cloning DNA by gap repair. Two procedures are described to repair a gapped plasmid using phage recombination functions. The colored segments with 5' and 3' ends represent 70-nt primers with 5' homology (yellow or red) segments and 3' ends (arrows) to amplify the plasmid vector to a linear form. (A) represents events used to retrieve a target gene from the bacterial chromosome by gap repair following electroporation of the linear vector. (B) represents cloning by co-electroporation of a linear vector with a linear PCR-amplified DNA having the same flanking homologies.

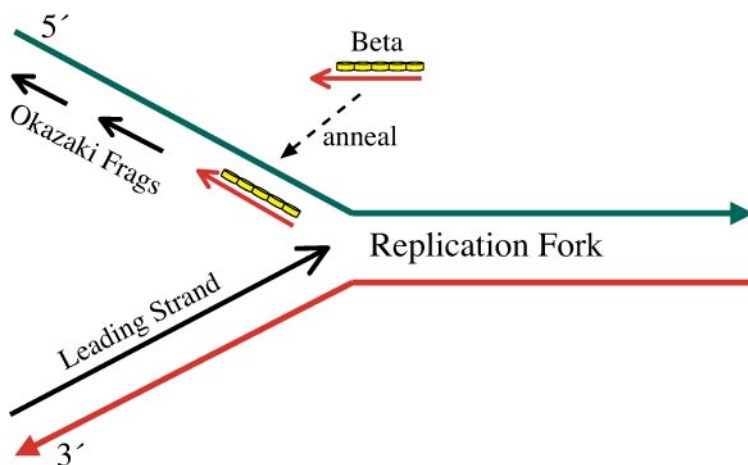

Figure 7 Annealing of the ssDNA oligo to the replication fork by Beta. A ssDNA oligo is shown bound by Beta. Beta anneals the ssDNA to the lagging strand gap at the replication fork.

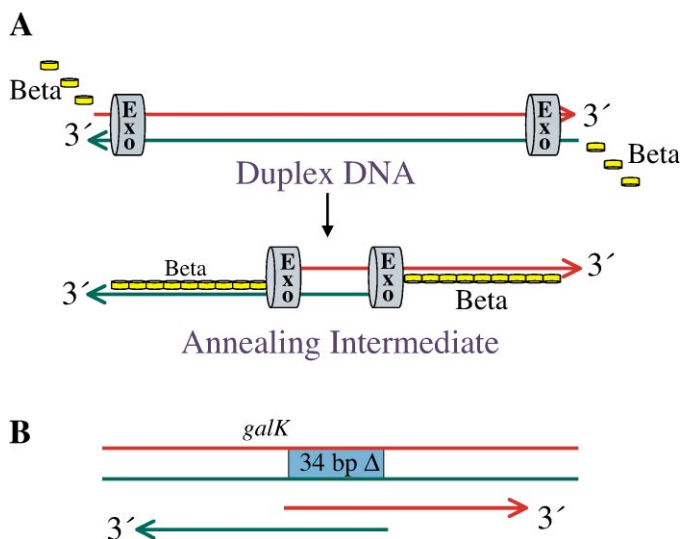

Figure 8 The dsDNA intermediate with 3' single-strand overhangs. (A) λ Exo and Beta generate an annealing intermediate from linear dsDNA. The 3' ends are indicated. (B) Recombination between a synthetic annealing intermediate and the bacterial chromosome at the *galK* gene. The *galK* gene contains a 34-bp deletion as indicated. In the annealing intermediate, the 3' overhangs are 36 nt long and the duplex segment is 34 bp in length.

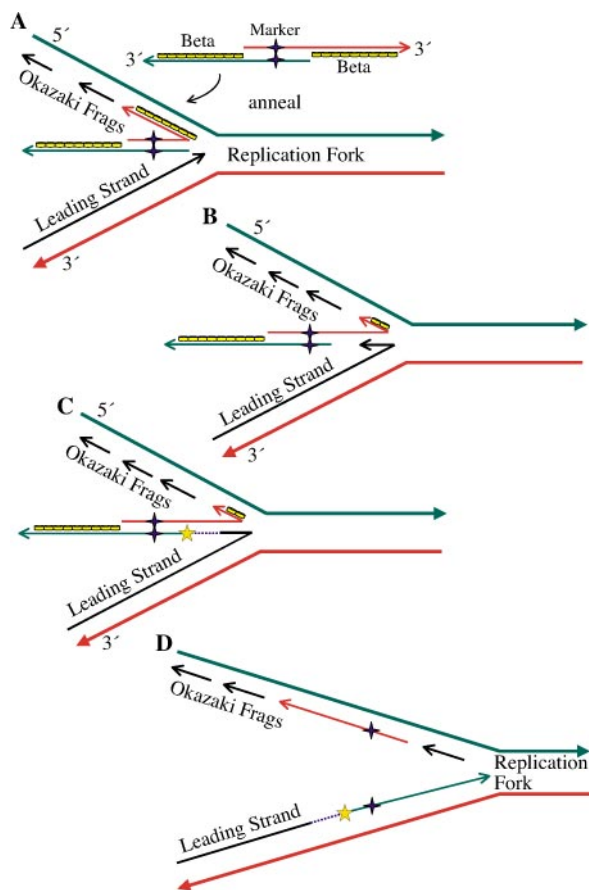

Figure 9 Recombination of a dsDNA intermediate at the replication fork. The dsDNA intermediate described in Figure 8A is shown with 3' overhangs. A genetic marker is indicated by blue stars. (A) The annealing of one 3' overhang with the leading strand gap. (B) Arrest and backtracking of the replication fork stimulated by Beta-mediated annealing of the ssDNA end with the leading strand. (C) PolA-catalyzed polymerization at the 3' end of the leading strand (blue dashes) and joining of that strand to the intermediate by DNA ligase (yellow star). (D) The re-established replication fork after branch migration to the right.

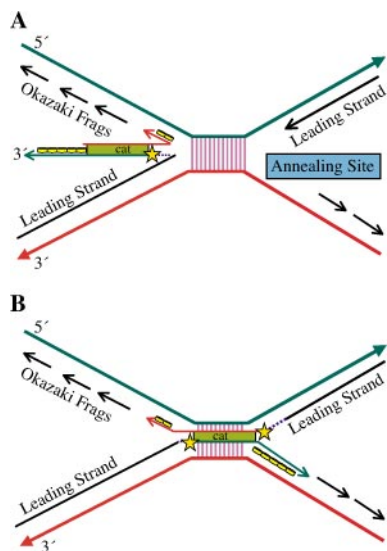

Figure 10 Recombination of a dsDNA containing large internal nonhomologies. In this model, the *cat* cassette represents the nonhomologous marker and is shown in place of the blue marker described in Figure 9. The nonhomology prevents branch migration to the right and the fork becomes moribund. (A) The second *E. coli* replication fork arriving at the position of the stalled fork. Vertical lines indicate base pairing between the unreplicated parental strands. The annealing site in the gap of the lagging strand at the second replication fork is complementary to the free 3' end of the dsDNA intermediate. (B) The structure after annealing of the free intermediate strand and joining of the leading strand to the *cat* cassette. Note that the original parental segment shown with base pairing (vertical lines) has not been replicated, and the *cat* substitution has been folded over during annealing and ligation, leaving cross-over junctions at each end that must still be resolved.

CONTENTS

FRONTISPIECE— <i>R. C. Lewontin</i>	xii
DIRECTIONS IN EVOLUTIONARY BIOLOGY, <i>R. C. Lewontin</i>	1
GENETIC MATING SYSTEMS AND REPRODUCTIVE NATURAL HISTORIES OF FISHES: LESSONS FOR ECOLOGY AND EVOLUTION, <i>John C. Avise, Adam G. Jones, DeEtte Walker, J. Andrew DeWoody, and collaborators</i>	19
GENETICS OF MOTILITY AND CHEMOTAXIS OF A FASCINATING GROUP OF BACTERIA: THE SPIROCHETES, <i>Nyles W. Charon and Stuart F. Goldstein</i>	47
RECOMBINATION IN EVOLUTIONARY GENOMICS, <i>David Posada, Keith A. Crandall, and Edward C. Holmes</i>	75
DEVELOPMENT AND FUNCTION OF THE ANGIOSPERM FEMALE GAMETOPHYTE, <i>Gary N. Drews and Ramin Yadegari</i>	99
PRIMORDIAL GENETICS: PHENOTYPE OF THE RIBOCYTE, <i>Michael Yarus</i>	125
STUDYING GENE FUNCTION IN EUKARYOTES BY CONDITIONAL GENE INACTIVATION, <i>Manfred Gossen and Hermann Bujard</i>	153
DNA TOPOLOGY-MEDIATED CONTROL OF GLOBAL GENE EXPRESSION IN <i>ESCHERICHIA COLI</i> , <i>G. Wesley Hatfield and Craig J. Benham</i>	175
MEIOTIC RECOMBINATION AND CHROMOSOME SEGREGATION IN <i>DROSOPHILA</i> FEMALES, <i>Kim S. McKim, Janet K. Jang, and Elizabeth A. Manheim</i>	205
<i>XIST</i> RNA and the Mechanism of X Chromosome Inactivation, <i>Kathrin Plath, Susanna Mlynarczyk-Evans, Dmitri A. Nusinow, and Barbara Panning</i>	233
ORIGINS OF SPONTANEOUS MUTATIONS: SPECIFICITY AND DIRECTIONALITY OF BASE-SUBSTITUTION, FRAMESHIFT, AND SEQUENCE-SUBSTITUTION MUTAGENESSES, <i>Hisaji Maki</i>	279
GENETICS OF INFLUENZA VIRUSES, <i>David A. Steinhauer and John J. Skehel</i>	305
ALLOSTERIC CASCADE OF SPLICEOSOME ACTIVATION, <i>David A. Brow</i>	333
GENETIC ENGINEERING USING HOMOLOGOUS RECOMBINATION, <i>Donald L. Court, James A. Sawitzke, and Lynn C. Thomason</i>	361

CHROMOSOME REARRANGEMENTS AND TRANSPOSABLE ELEMENTS, <i>Wolf-Ekkehard Lönnig and Heinz Suedler</i>	389
GENETICS OF SENSORY MECHANOTRANSDUCTION, <i>Glen G. Ernstrom and Martin Chalfie</i>	411
UNDERSTANDING THE FUNCTION OF ACTIN-BINDING PROTEINS THROUGH GENETIC ANALYSIS OF <i>DROSOPHILA</i> OOGENESIS, <i>Andrew M. Hudson and Lynn Cooley</i>	455
THE GENETICS OF RNA SILENCING, <i>Marcel Tijsterman, René F. Ketting, and Ronald H. A. Plasterk</i>	489
TRANSVLECTION EFFECTS IN <i>DROSOPHILA</i> , <i>Ian W. Duncan</i>	521
GENETICS OF <i>CRYPTOCOCCUS NEOFORMANS</i> , <i>Christina M. Hull and Joseph Heitman</i>	557
TOWARD MAINTAINING THE GENOME: DNA DAMAGE AND REPLICATION CHECKPOINTS, <i>Kara A. Nyberg, Rhett J. Michelson, Charles W. Putnam, and Ted A. Weinert</i>	617
THE FELINE GENOME PROJECT, <i>Stephen J. O'Brien, Marilyn Menotti-Raymond, William J. Murphy, and Naoya Yuhki</i>	657
GENETIC APPROACHES TO MOLECULAR AND CELLULAR COGNITION: A FOCUS ON LTP AND LEARNING AND MEMORY, <i>Anna Matynia, Steven A. Kushner, and Alcino J. Silva</i>	687
ESTIMATING F-STATISTICS, <i>B. S. Weir and W. G. Hill</i>	721
INDEXES	
Subject Index	751
Cumulative Index of Contributing Authors, Volumes 32–36	787
Cumulative Index of Chapter Titles, Volumes 32–36	790
ERRATA	
An online log of corrections to <i>Annual Review of Genetics</i> chapters may be found at http://genet.annualreviews.org/errata.shtml	